

SPECIFICATION



TRACKED EXCAVATOR | JZ140 LC

Gross engine power: 81 kW (109 hp) | Bucket capacity: 0.35 – 0.89m³ | Operating weight: 15084 – 16826kg



STATIC DIMENSIONS

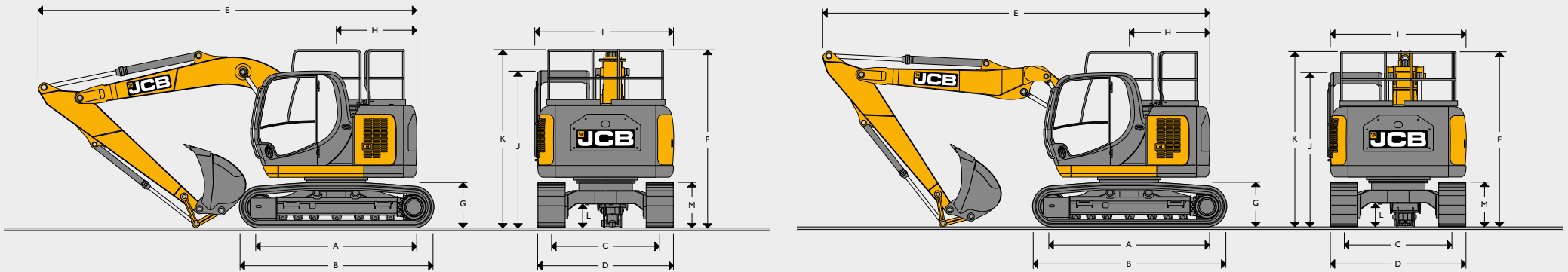

STATIC DIMENSIONS

Dimensions in mm		Monoboom						T.A.B.					
		LC						LC					
A	Track length on ground	2865						2865					
B	Undercarriage overall length	3590						3590					
C	Track gauge	1990						1990					
D	Width over tracks (500mm trackshoes)	2490						2490					
D	Width over tracks (600mm trackshoes)	2590						2590					
D	Width over tracks (700mm trackshoes)	2690						2690					
D	Width over tracks (850mm trackshoes)	2840						2840					
Boom options		Monoboom 4.7m						T.A.B. 5.0m					
Dipper lengths		2.5m	2.7m	3.0m	2.5m	2.7m	3.0m	2.5m	2.7m	3.0m	2.5m	2.7m	3.0m
E	Transport length	7331	7275	7284	7331	7275	7284	7591	7522	7440	7591	7522	7440
F	Transport height	3227	3300	3318	3337	3410	3428	3227	3227	3233	3337	3337	3343
G	Counterweight clearance		916			1026			916				1026
H	Tailswing radius		1485			1485			1485				1485
I	Width of superstructure		2500			2500			2500				2500
J	Height over cab		2842			2952			2842				2952
K	Height over grab rail		3227			3337			3227				3337
L	Ground clearance		434			440			434				440
M	Track height		820			832			820				832

ENGINE	
Model	JCB Dieselmex 448 TCA EU Stage V
Type	Water cooled, 4-stroke, 4-cylinder in-line, common rail direct injection, turbocharged variable geometry intercooled diesel.
Rated power (net)	81 kW (109hp) at 2200rpm (ISO 14396)
Piston displacement	4.765L
Air filtration	Dry element with secondary safety element and in-cab warning indicator.
Starting system	24 volt.
Batteries	2 x 12 volt.
Alternator	24 volt 100 ampere

SLEW SYSTEM	
Slew motor	Axial piston type.
Slew brake	Hydraulic braking plus automatic spring applied disc type parking brake.
Slew torque	36.1 kNm
Slew speed	13.1 rpm.
Slew gear	Large diameter, internally toothed fully sealed grease bath lubricated.

TRACK DRIVE	
Type	Fully hydrostatic, two speed with autoshift.
Travel motors	Variable swash axial piston type, fully guarded within undercarriage frame.
Final drive	Planetary reduction, bolt-on sprockets.
Service brake	Hydraulic counter balance valve.
Park brake	Disc type, spring applied, automatic hydraulic release.
Gradability	70% (35 deg) continuous.
Travel speed	LC
	High - 5.12 km/h
	Low - 3.00 km/h
Tractive effort	120.5 kNm

SERVICE CAPACITIES	
	Litres
Fuel tank	193.7L
Engine coolant	23.6
Engine oil	14
Swing reduction gear	2.2
Track reduction gear (each side)	3.5
Hydraulic system	160
Hydraulic tank	67
DEF tank	18.5

UNDERCARRIAGE				
Carriage options	LC - Long Carriage			
Construction	Fully welded 'X' Frame type and sloping sidemembers with dirt relief holes under top rollers.			
Recovery point	Front and rear.			
Track shoes	500mm	600mm	700mm	850mm
LC	● X	●	●	●
Upper & lower rollers	Heat treated, sealed and lubricated.			
Track adjustment	Grease cylinder type.			
Track idler	Sealed and lubricated, with spring cushioned recoil.			
Track type	Sealed and lubricated.			
Rollers and shoes (each side)	LC			
No. of track guides (optional)	2			
No. of lower rollers	7			
No. of upper rollers	2			
No. of track shoes	44			

● = Triple grouser, **X** = Geogrip.

HYDRAULIC SYSTEM

Open centered, negative control hydraulic system with twin variable flow piston pumps providing flow-on-demand.

Pumps

Main pumps	2 variable displacement axial piston type.
Maximum flow	2 x 124 l/min.
Servo pump	Gear type.
Maximum flow	20.5 l/min.

Control valve

A combined four and five spool control valve with auxiliary service spool as standard.

Relief valve settings

Boom/Arm/Bucket	314 bar.
With power boost	343 bar.
Slew circuit	279 bar.
Travel circuit	343 bar.
Pilot control	40 bar.

Filtration

In tank	150 micron, suction strainer.
Main return line	10 micron, glass fibre element.
Pilot line	10 micron, paper element.
Hydraulic hammer return	10 micron, reinforced microform element.

WEIGHTS AND GROUND BEARING PRESSURES

Figures include 383kg bucket, operator, full fuel tank and 2.5m dipper.

		500mm shoes	600mm shoes	700mm shoes	850mm shoes
LC Monoboam					
Machine weight	kg	15084	15300	15515	15839
Ground bearing pressure	kg/cm ²	0.48	0.41	0.35	0.30
LC T.A.B.					
Machine weight	kg	15607	15823	16038	16361
Ground bearing pressure	kg/cm ²	0.50	0.42	0.37	0.31
LC Mono Dozer					
Machine weight	kg	15856	16079	16304	-
Ground bearing pressure	kg/cm ²	0.51	0.43	0.37	-
LC T.A.B. Dozer					
Machine weight	kg	16378	16602	16826	-
Ground bearing pressure	kg/cm ²	0.52	0.44	0.38	-

OPTIONAL BLADE

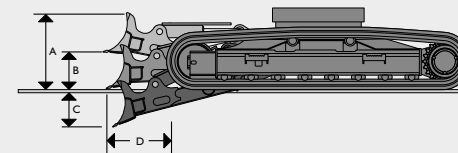

A	Blade height	mm	447
B	Blade lift above ground	mm	494
C	Blade cut below ground	mm	508
D	Blade forward of track	mm	412
	Dozer width – 500mm tracks	mm	2510
	Dozer width – 600mm tracks	mm	2610
	Dozer width – 700mm tracks	mm	2710
Additional machine weight with blade			
	500mm tracks	kg	636
	600mm tracks	kg	644
	700mm tracks	kg	653

Dozer not available with 850.

BUCKET AND ARM COMBINATION - MONOBOOM

Bucket options		GP Bucket						HD Bucket						Grade Bucket		
Bucket width	mm	600	700	800	1000	1200	1300	600	700	800	1000	1200	1300	1524	1836	1836
Bucket capacity	m ³	0.35	0.42	0.50	0.66	0.81	0.89	0.35	0.42	0.50	0.66	0.81	0.89	0.65	0.79	0.79
Bucket weight	kg	286	312	335	383	428	454	336	364	402	455	520	546	453	523	582
LC																
2.50m Quickhitch (No Quickhitch)		☐ (☐)	☐ (☐)	☐ (☐)	☐ (☐)	■ (☐)	■ (■)	☐ (☐)	☐ (☐)	☐ (☐)	☐ (☐)	■ (☐)	■ (■)	☐ (☐)	■ (☐)	■ (☐)
2.70m Quickhitch (No Quickhitch)		☐ (☐)	☐ (☐)	☐ (☐)	☐ (☐)	■ (☐)	■ (■)	☐ (☐)	☐ (☐)	☐ (☐)	☐ (☐)	■ (■)	● (■)	☐ (☐)	■ (☐)	■ (■)
3.00m Quickhitch (No Quickhitch)		☐ (☐)	☐ (☐)	☐ (☐)	☐ (☐)	■ (■)	● (■)	☐ (☐)	☐ (☐)	☐ (☐)	☐ (☐)	● (■)	● (●)	☐ (☐)	● (■)	● (■)
LC + Dozer																
2.50m Quickhitch (No Quickhitch)		☐ (☐)	☐ (☐)	☐ (☐)	☐ (☐)	☐ (☐)	☐ (☐)	☐ (☐)	☐ (☐)	☐ (☐)	☐ (☐)	☐ (☐)	■ (☐)	☐ (☐)	☐ (☐)	■ (☐)
2.70m Quickhitch (No Quickhitch)		☐ (☐)	☐ (☐)	☐ (☐)	☐ (☐)	☐ (☐)	■ (■)	☐ (☐)	☐ (☐)	☐ (☐)	☐ (☐)	■ (☐)	■ (■)	☐ (☐)	■ (☐)	■ (☐)
3.00m Quickhitch (No Quickhitch)		☐ (☐)	☐ (☐)	☐ (☐)	☐ (☐)	■ (☐)	■ (■)	☐ (☐)	☐ (☐)	☐ (☐)	☐ (☐)	■ (■)	● (■)	☐ (☐)	■ (■)	■ (■)

BUCKET AND ARM COMBINATION - T.A.B.

Bucket options		GP Bucket						HD Bucket						Grade Bucket		
Bucket width	mm	600	700	800	1000	1200	1300	600	700	800	1000	1200	1300	1524	1836	1836
Bucket capacity	m ³	0.35	0.42	0.50	0.66	0.81	0.89	0.35	0.42	0.50	0.66	0.81	0.89	0.65	0.79	0.79
Bucket weight	kg	286	312	335	383	428	454	336	364	402	455	520	546	453	523	582
LC																
2.50m Quickhitch (No Quickhitch)		☐ (☐)	☐ (☐)	☐ (☐)	☐ (☐)	■ (■)	● (■)	☐ (☐)	☐ (☐)	☐ (☐)	■ (☐)	● (■)	● (●)	■ (☐)	● (■)	● (■)
2.70m Quickhitch (No Quickhitch)		☐ (☐)	☐ (☐)	☐ (☐)	■ (☐)	● (■)	● (●)	☐ (☐)	☐ (☐)	☐ (☐)	■ (☐)	● (■)	● (●)	■ (☐)	● (■)	● (●)
3.00m Quickhitch (No Quickhitch)		☐ (☐)	☐ (☐)	☐ (☐)	■ (☐)	● (●)	● (●)	☐ (☐)	☐ (☐)	☐ (☐)	■ (■)	● (●)	× (●)	■ (■)	● (●)	● (●)
LC + Dozer																
2.50m Quickhitch (No Quickhitch)		☐ (☐)	☐ (☐)	☐ (☐)	☐ (☐)	■ (☐)	● (■)	☐ (☐)	☐ (☐)	☐ (☐)	☐ (☐)	■ (■)	● (■)	☐ (☐)	■ (■)	■ (■)
2.70m Quickhitch (No Quickhitch)		☐ (☐)	☐ (☐)	☐ (☐)	☐ (☐)	■ (■)	● (■)	☐ (☐)	☐ (☐)	☐ (☐)	■ (☐)	● (■)	● (●)	☐ (☐)	● (■)	● (■)
3.00m Quickhitch (No Quickhitch)		☐ (☐)	☐ (☐)	☐ (☐)	■ (☐)	● (■)	● (●)	☐ (☐)	☐ (☐)	☐ (☐)	■ (☐)	● (■)	● (●)	■ (☐)	● (■)	● (●)

- = Material weight up to 1200kg/m³.
- = Material weight up to 1600kg/m³.
- ☐ = Material weight up to 2000kg/m³.

These recommendations are given as a guide based on typical operating conditions.
Please contact your distributor for the correct selection of buckets and attachments to suit the application.

WORKING RANGE - LC MONOBOOM 4.7M







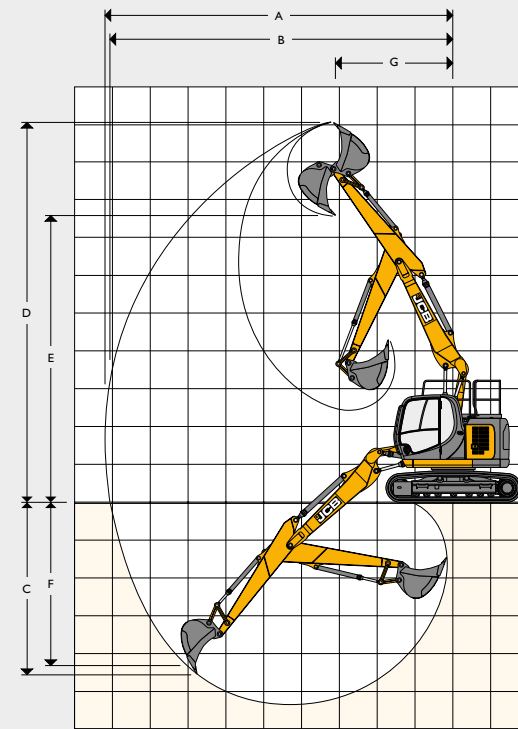
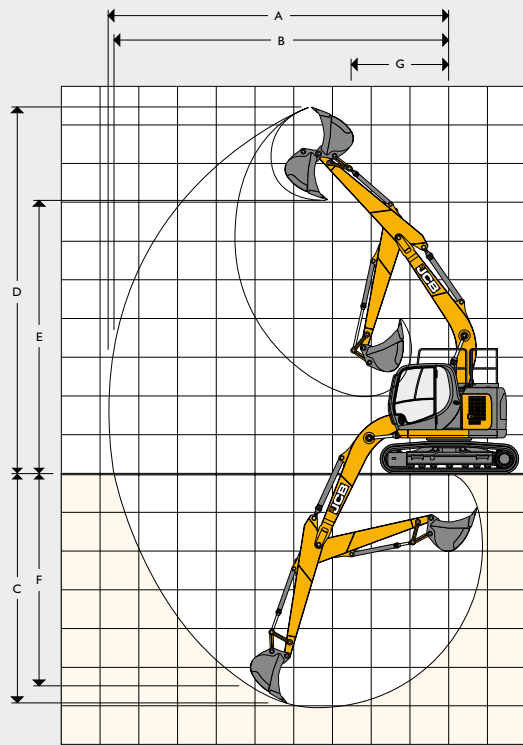







Dipper length:		2.5m	2.7m	3.0m	
A	Maximum digging reach	mm	8331	8465	8787
B	Maximum digging reach (on ground)	mm	8187	8324	8651
C	Maximum digging depth	mm	5557	5762	6055
D	Maximum digging height	mm	9160	9275	9469
E	Maximum dumping height	mm	6692	6807	7015
F	Maximum vertical wall cut depth	mm	4986	5073	5488
G	Minimum swing radius	mm	2175	2468	2535
	Bucket rotation	deg	182	182	182
	Maximum dipper tearout	kNm	66.3	64.8	60.1
	Maximum bucket tearout	kNm	92	92	92

WORKING RANGE - LC T.A.B. 5.0M















Dipper length:		2.5m	2.7m	3.0m	
A	Maximum digging reach	mm	8742	8884	9217
B	Maximum digging reach (on ground)	mm	8608	8754	9090
C	Maximum digging depth	mm	4883	5183	5382
D	Maximum digging height	mm	9654	9733	10030
E	Maximum dumping height	mm	7186	7289	7562
F	Maximum vertical wall cut depth	mm	3909	4016	4336
G	Minimum swing radius	mm	2691	3090	3109
	Bucket rotation	deg	182	182	182
	Maximum dipper tearout	kNm	66.3	64.8	60.1
	Maximum bucket tearout	kNm	92	92	92















LIFT CAPACITIES – DIPPER LENGTH: 2.5M, 4.7M MONOBOOM, TRACKSHOES: 500MM, NO BUCKET **JZ140 LC MONO**

Reach	2m		3m		4m		5m		6m		7m		Capacity at Max Reach			
																
Load Point Ht.	kg	kg	kg	kg	kg	kg	kg	kg	kg	kg	kg	kg	kg	kg	kg	mm
6.0m					3450*	3450*	3660*	3180						2360*	2360*	5490
5.0m					3670*	3670*	3720*	3160	2970*	2320				2220*	2190	6179
4.0m			4720*	4720*	4280*	4280*	4030*	3090	3350	2300				2160*	1920	6648
3.0m			6560*	6560*	5190*	4190	4390*	2980	3290	2240				2160*	1760	6941
2.0m			8610*	6070	6050*	3950	4250	2850	3210	2170	2520	1700		2220*	1670	7080
1.0m			6750*	5710	5820	3750	4120	2730	3140	2100	2490	1670		2330*	1640	7076
0m			7090*	5550	5670	3620	4030	2650	3080	2050				2500*	1670	6926
- 1.0m	4840*	4840*	9110*	5510	5600	3560	3970	2600	3050	2020				2650	1770	6623
- 2.0m	7500*	7500*	9310	5530	5590	3550	3960	2590	3050	2030				2960	1970	6141
- 3.0m	10940*	10940*	9090*	5600	5640	3590	4000	2620						3560	2360	5435

LIFT CAPACITIES – DIPPER LENGTH: 2.5M, 4.7M MONOBOOM, TRACKSHOES: 500MM, NO BUCKET, DOZER **JZ140 LC MONO**

Reach	2m		3m		4m		5m		6m		7m		Capacity at Max Reach			
																
Load Point Ht.	kg	kg	kg	kg	kg	kg	kg	kg	kg	kg	kg	kg	kg	kg	kg	mm
6.0m					3450*	3450*	3660*	3330						2360*	2360*	5490
5.0m					3670*	3670*	3720*	3320	2970*	2440				2220*	2220*	6179
4.0m			4720*	4720*	4280*	4280*	4030*	3250	3370	2420				2160*	2030	6648
3.0m			6560*	6560*	5190*	4400	4420	3140	3310	2370				2160*	1860	6941
2.0m			8610*	6390	6090*	4160	4280	3010	3240	2300	2550	1810		2220*	1770	7080
1.0m			6750*	6030	5860	3960	4150	2890	3160	2230	2510	1770		2330*	1750	7076
0m			7090*	5870	5710	3830	4060	2800	3100	2180				2520	1780	6926
- 1.0m	4840*	4840*	9110*	5820	5640	3770	4000	2750	3070	2150				2680	1880	6623
- 2.0m	7500*	7500*	9380	5840	5630	3760	3990	2740	3080	2150				2990	2090	6141
- 3.0m	10940*	10940*	9090*	5920	5670	3800	4030	2780						3590	2500	5435





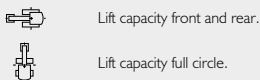









LIFT CAPACITIES – DIPPER LENGTH: 2.7M, 4.7M MONOBOOM, TRACKSHOES: 500MM, NO BUCKET **JZ140 LC MONO**

Reach	2m		3m		4m		5m		6m		7m		Capacity at Max Reach			
																
Load Point Ht.	kg	kg	kg	kg	kg	kg	kg	kg	kg	kg	kg	kg	kg	kg	kg	mm
6.0m					3200*	3200*	3480*	3210						2470*	2470*	5720
5.0m					3430*	3430*	3530*	3190	3390	2340				2340*	2080	6384
4.0m					4030*	4030*	3840*	3110	3360	2310				2290*	1830	6839
3.0m			6110*	6110*	4940*	4220	4350*	2990	3300	2250	2560	1740		2290*	1680	7124
2.0m			8180*	6140	5980*	3980	4260	2860	3210	2170	2520	1700		2350*	1600	7260
1.0m			7560*	5730	5840	3760	4120	2730	3130	2100	2480	1660		2350	1570	7255
0m			7290*	5530	5670	3610	4020	2640	3070	2040	2450	1630		2400	1600	7110
- 1.0m	4700*	4700*	8960*	5460	5580	3530	3950	2580	3030	2000				2530	1680	6814
- 2.0m	7130*	7130*	9250	5470	5550	3510	3930	2560	3020	2000				2800	1860	6348
- 3.0m	10290*	10290*	9310*	5540	5590	3550	3960	2590						3330	2200	5667











- Notes:**
1. For lifting capacity including bucket, subtract total weight of bucket or bucket and quickhitch from above values.
 2. Lifting capacities are based on ISO 10567, that is: 75% of minimum tipping load or 87% of hydraulic lift capacity, whichever is the less. Lifting capacities marked* are based on hydraulic capacity.
 3. Lift capacities assume that the machine is on firm, level ground.
 4. Lift capacities may be limited by local regulations. Please refer to your dealer.









LIFT CAPACITIES – DIPPER LENGTH: 2.7M, 4.7M MONOBOOM, TRACKSHOES: 500MM, NO BUCKET, DOZER **JZ140 LC MONO**

Reach	2m		3m		4m		5m		6m		7m		Capacity at Max Reach			
																
Load Point Ht.	kg	kg	kg	kg	kg	kg	kg	kg	kg	kg	kg	kg	kg	kg	mm	
6.0m					3200*	3200*	3480*	3370						2470*	2470*	5720
5.0m					3430*	3430*	3530*	3350	3420	2470				2340*	2200	6384
4.0m					4030*	4030*	3840*	3270	3390	2440				2290*	1940	6839
3.0m			6110*	6110*	4940*	4440	4350*	3150	3320	2370	2590	1840		2290*	1790	7124
2.0m			8180*	6460	5980*	4190	4290	3020	3240	2300	2550	1810		2350*	1700	7260
1.0m			7560*	6050	5870	3970	4150	2890	3160	2230	2510	1770		2370	1670	7255
0m			7290*	5850	5700	3820	4050	2790	3100	2170	2470	1740		2420	1700	7110
- 1.0m	4700*	4700*	8960*	5780	5610	3740	3980	2740	3060	2130				2560	1790	6814
- 2.0m	7130*	7130*	9310	5790	5590	3720	3960	2720	3050	2120				2830	1980	6348
- 3.0m	10290*	10290*	9310*	5860	5630	3760	3990	2740						3350	2340	5667

LIFT CAPACITIES – DIPPER LENGTH: 3.0M, 4.7M MONOBOOM, TRACKSHOES: 500MM, NO BUCKET **JZ140 LC MONO**







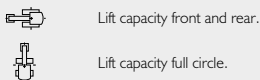







Reach	2m		3m		4m		5m		6m		7m		Capacity at Max Reach			
																
Load Point Ht.	kg	kg	kg	kg	kg	kg	kg	kg	kg	kg	kg	kg	kg	kg	mm	
6.0m							3150*	3150*	2380*	2350				2160*	2160*	6070
5.0m							3230*	3220	3360*	2370				2050*	1930	6699
4.0m					3650*	3650*	3570*	3140	3380	2330	2490*	1770		2010*	1710	7133
3.0m			5440*	5440*	4560*	4280	4090*	3020	3310	2260	2570	1750		2020*	1580	7407
2.0m			7540*	6270	5630*	4020	4290	2880	3220	2180	2530	1700		2070*	1500	7538
1.0m			9270*	5800	5870	3790	4140	2740	3140	2100	2480	1660		2170*	1470	7533
0m			7810*	5540	5680	3620	4020	2630	3060	2030	2440	1620		2250	1490	7393
- 1.0m	4620*	4620*	8850*	5440	5560	3520	3940	2560	3010	1980	2420	1600		2360	1570	7110
- 2.0m	6660*	6660*	9200	5420	5520	3480	3900	2530	2990	1970				2590	1710	6664
- 3.0m	9310*	9310*	9260	5470	5540	3500	3920	2540	3030	2000				3010	1990	6020















LIFT CAPACITIES – DIPPER LENGTH: 3.0M, 4.7M MONOBOOM, TRACKSHOES: 500MM, NO BUCKET, DOZER **JZ140 LC MONO**















Reach	2m		3m		4m		5m		6m		7m		Capacity at Max Reach			
																
Load Point Ht.	kg	kg	kg	kg	kg	kg	kg	kg	kg	kg	kg	kg	kg	kg	mm	
6.0m							3150*	3150*	2380*	2380*				2160*	2160*	6070
5.0m							3230*	3230*	3360*	2490				2050*	2040	6699
4.0m					3650*	3650*	3570*	3300	3410	2450	2490*	1880		2010*	1810	7133
3.0m			5440*	5440*	4560*	4490	4090*	3180	3340	2390	2600	1850		2020*	1670	7407
2.0m			7540*	6590	5630*	4230	4320	3040	3250	2310	2550	1810		2070*	1600	7538
1.0m			9270*	6120	5910	4000	4170	2900	3160	2220	2500	1760		2170*	1570	7533
0m			7810*	5860	5710	3830	4050	2790	3090	2160	2460	1720		2270	1590	7393
- 1.0m	4620*	4620*	8850*	5760	5600	3730	3970	2720	3040	2110	2440	1700		2390	1670	7110
- 2.0m	6660*	6660*	9260	5740	5560	3690	3930	2690	3020	2090				2620	1820	6664
- 3.0m	9310*	9310*	9320	5790	5580	3710	3950	2700	3050	2130				3040	2120	6020



- Notes:**
1. For lifting capacity including bucket, subtract total weight of bucket or bucket and quickhitch from above values.
 2. Lifting capacities are based on ISO 10567, that is: 75% of minimum tipping load or 87% of hydraulic lift capacity, whichever is the less. Lifting capacities marked* are based on hydraulic capacity.
 3. Lift capacities assume that the machine is on firm, level ground.
 4. Lift capacities may be limited by local regulations. Please refer to your dealer.

LIFT CAPACITIES – DIPPER LENGTH: 2.5M, 5.0M T.A.B., TRACKSHOES: 500MM, NO BUCKET															JZ140 LC T.A.B.
Reach	2m		3m		4m		5m		6m		7m		Capacity at Max Reach		
															
Load Point Ht.	kg	kg	kg	kg	kg	kg	kg	kg	kg	kg	kg	kg	kg	kg	mm
6.0m					3490*	3490*	3550*	3210	2530*	2280			2430*	2270	6014
5.0m					3800*	3800*	3660*	3170	3400	2310			2260*	1890	6649
4.0m			5080*	5080*	4440*	4380	4000*	3060	3350	2270	2560	1710	2180*	1670	7086
3.0m					5320*	4100	4360	2920	3260	2190	2540	1690	2160*	1530	7361
2.0m					5940	3810	4190	2760	3170	2100	2490	1650	2170*	1460	7493
1.0m					5680	3580	4040	2620	3080	2020	2440	1600	2200	1440	7488
0m					5520	3440	3930	2520	3010	1960	2410	1570	2250	1460	7347
- 1.0m			6010*	5260	5460	3380	3870	2470	2970	1920	2400	1560	2370	1550	7062
- 2.0m	5440*	5440*	9000*	5300	5460	3380	3860	2460	2970	1920			2620	1710	6613
- 3.0m			8640*	5400	5520	3440	3900	2500					3070	2010	5964





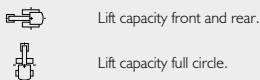









LIFT CAPACITIES – DIPPER LENGTH: 2.5M, 5.0M T.A.B., TRACKSHOES: 500MM, NO BUCKET, DOZER															JZ140 LC T.A.B.
Reach	2m		3m		4m		5m		6m		7m		Capacity at Max Reach		
															
Load Point Ht.	kg	kg	kg	kg	kg	kg	kg	kg	kg	kg	kg	kg	kg	kg	mm
6.0m					3490*	3490*	3550*	3370	2530*	2400			2430*	2390	6014
5.0m					3800*	3800*	3660*	3320	3420	2440			2260*	2000	6649
4.0m			5080*	5080*	4440*	4440*	4000*	3220	3370	2390	2580	1820	2180*	1770	7086
3.0m					5320*	4310	4390	3070	3290	2320	2560	1800	2160*	1630	7361
2.0m					5980	4020	4220	2920	3190	2230	2510	1750	2170*	1560	7493
1.0m					5720	3790	4070	2780	3100	2140	2460	1710	2220	1540	7488
0m					5560	3650	3960	2680	3030	2080	2430	1670	2270	1560	7347
- 1.0m			6010*	5580	5500	3590	3900	2630	3000	2050	2420	1670	2390	1650	7062
- 2.0m	5440*	5440*	9000*	5620	5500	3590	3890	2620	3000	2050			2640	1820	6613
- 3.0m			8640*	5720	5560	3650	3930	2660					3100	2130	5964

LIFT CAPACITIES – DIPPER LENGTH: 2.7M, 5.0M T.A.B., TRACKSHOES: 500MM, NO BUCKET															JZ140 LC T.A.B.
Reach	2m		3m		4m		5m		6m		7m		Capacity at Max Reach		
															
Load Point Ht.	kg	kg	kg	kg	kg	kg	kg	kg	kg	kg	kg	kg	kg	kg	mm
6.0m							3370*	3240	3410*	2330			2540*	2130	6248
5.0m					3580*	3580*	3500*	3200	3240	2340			2390*	1800	6860
4.0m			4130*	4130*	4210*	4210*	3840*	3090	3360	2280	2580	1730	2300*	1590	7285
3.0m					5090*	4140	4340*	2940	3270	2200	2540	1700	2220	1470	7553
2.0m					5980	3840	4210	2770	3170	2110	2490	1650	2140	1400	7681
1.0m					5690	3590	4040	2620	3070	2020	2440	1600	2110	1380	7677
0m					5520	3430	3920	2510	3000	1950	2390	1560	2150	1400	7539
- 1.0m			5880*	5200	5430	3360	3850	2450	2950	1900	2380	1540	2260	1470	7262
- 2.0m	5140*	5140*	8580*	5240	5420	3340	3830	2430	2940	1900			2480	1610	6826
- 3.0m			8860*	5330	5470	3390	3870	2460	2990	1940			2880	1880	6199

















- Notes:
1. For lifting capacity including bucket, subtract total weight of bucket or bucket and quickhitch from above values.
 2. Lifting capacities are based on ISO 10567, that is: 75% of minimum tipping load or 87% of hydraulic lift capacity, whichever is the less. Lifting capacities marked* are based on hydraulic capacity.
 3. Lift capacities assume that the machine is on firm, level ground.
 4. Lift capacities may be limited by local regulations. Please refer to your dealer.

LIFT CAPACITIES – DIPPER LENGTH: 2.7M, 5.0M T.A.B., TRACKSHOES: 500MM, NO BUCKET, DOZER **JZ140 LC T.A.B.**

Reach	2m		3m		4m		5m		6m		7m		Capacity at Max Reach			
																mm
Load Point Ht.	kg	kg	kg	kg	kg	kg	kg	kg	kg	kg	kg	kg	kg	kg	kg	mm
6.0m							3370*	3370*	3410*	2450				2540*	2250	6248
5.0m					3580*	3580*	3500*	3350	3450	2460				2390*	1900	6860
4.0m			4130*	4130*	4210*	4210*	3840*	3240	3390	2410	2600	1840		2300*	1690	7285
3.0m					5090*	4350	4340*	3090	3300	2330	2570	1800		2240	1560	7553
2.0m					6020	4050	4230	2930	3200	2230	2510	1750		2160	1490	7681
1.0m					5730	3800	4070	2780	3100	2140	2460	1700		2130	1470	7677
0m					5550	3640	3950	2670	3020	2070	2420	1660		2170	1490	7539
- 1.0m			5880*	5520	5470	3570	3880	2610	2980	2030	2400	1640		2290	1570	7262
- 2.0m	5140*	5140*	8580*	5550	5460	3560	3860	2590	2970	2020				2500	1720	6826
- 3.0m			8860*	5640	5510	3600	3900	2620	3020	2070				2910	2000	6199

LIFT CAPACITIES – DIPPER LENGTH: 3.0M, 5.0M T.A.B., TRACKSHOES: 500MM, NO BUCKET **JZ140 LC T.A.B.**

Reach	2m		3m		4m		5m		6m		7m		Capacity at Max Reach			
																mm
Load Point Ht.	kg	kg	kg	kg	kg	kg	kg	kg	kg	kg	kg	kg	kg	kg	kg	mm
6.0m							3100*	3100*	3240*	2380				2210*	1950	6599
5.0m							3250*	3240	3250*	2370	2620	1760		2090*	1660	7182
4.0m					3760*	3760*	3600*	3130	3390	2310	2600	1750		2020*	1480	7588
3.0m					4750*	4210	4100*	2970	3330	2220	2560	1710		2010*	1370	7845
2.0m					5740*	3900	4240	2800	3190	2120	2500	1650		2010	1310	7969
1.0m					5740	3620	4060	2640	3080	2020	2430	1590		1990	1290	7965
0m					5530	3440	3920	2510	2990	1940	2380	1540		2020	1300	7833
- 1.0m			5870*	5170	5410	3340	3840	2430	2940	1880	2350	1520		2110	1360	7566
- 2.0m	4850*	4850*	8080*	5170	5380	3310	3800	2400	2910	1870	2360	1520		2300	1490	7149
- 3.0m	7270*	7270*	9070	5240	5410	3340	3820	2420	2940	1890				2630	1700	6553

LIFT CAPACITIES – DIPPER LENGTH: 3.0M, 5.0M T.A.B., TRACKSHOES: 500MM, NO BUCKET, DOZER **JZ140 LC T.A.B.**

Reach	2m		3m		4m		5m		6m		7m		Capacity at Max Reach			
																mm
Load Point Ht.	kg	kg	kg	kg	kg	kg	kg	kg	kg	kg	kg	kg	kg	kg	kg	mm
6.0m							3100*	3100*	3240*	2500				2210*	2060	6599
5.0m							3250*	3250*	3250*	2490	2640	1870		2090*	1760	7182
4.0m					3760*	3760*	3600*	3280	3420	2430	2630	1860		2020*	1580	7588
3.0m					4750*	4430	4100*	3130	3320	2340	2580	1810		2010*	1460	7845
2.0m					5740*	4110	4260	2950	3210	2240	2520	1750		2030*	1400	7969
1.0m					5780	3830	4090	2790	3100	2140	2460	1700		2010	1380	7965
0m					5560	3650	3950	2670	3020	2060	2410	1650		2040	1390	7833
- 1.0m			5870*	5490	5450	3550	3870	2590	2960	2010	2370	1620		2140	1460	7566
- 2.0m	4850*	4850*	8080*	5490	5420	3520	3830	2560	2940	1990	2380	1620		2320	1590	7149
- 3.0m	7270*	7270*	9130	5560	5450	3550	3850	2580	2970	2010				2930	1820	6553

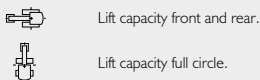

- Notes:
1. For lifting capacity including bucket, subtract total weight of bucket or bucket and quickhitch from above values.
 2. Lifting capacities are based on ISO 10567, that is: 75% of minimum tipping load or 87% of hydraulic lift capacity, whichever is the less. Lifting capacities marked* are based on hydraulic capacity.
 3. Lift capacities assume that the machine is on firm, level ground.
 4. Lift capacities may be limited by local regulations. Please refer to your dealer.





ONE COMPANY, OVER 300 MACHINES.

Your nearest JCB dealer

Tracked Excavator JZ140 LC

Gross engine power: 81 kW (109 hp)

Bucket capacity: 0.35 – 0.89m³ Operating weight: 15084 – 16826kg

JCB Sales Limited, Rokester, Staffordshire, United Kingdom ST14 5JP.

Tel: +44 (0)1889 590312 Email: salesinfo@jcb.com

Download the very latest information on this product range at: www.jcb.com

©2022 JCB Sales. All rights reserved. No part of this publication may be reproduced, stored in a retrieval system, or transmitted in any form or by any other means, electronic, mechanical, photocopying or otherwise, without prior permission from JCB Sales. All references in this publication to operating weights, sizes, capacities and other performance measurements are provided for guidance only and may vary dependant upon the exact specification of machine. They should not therefore be relied upon in relation to suitability for a particular application. Guidance and advice should always be sought from your JCB Dealer. JCB reserves the right to change specifications without notice. Illustrations and specifications shown may include optional equipment and accessories. All images are correct at time of print. The JCB logo is a registered trademark of J C Bamford Excavators Ltd.

